

Revised Bill of Quantity

S.No	Furniture Items- Size	Description	Unit	Qty	Rate	Amount	(PHOTOGRAPH ANNEXED IS ONLY FOR GUIDANCE). COMPLETE AS PER DIRECTION AND SATISFACTION OF ENGINEER IN-CHARGE.
1	Storage	Providing and fixing of storage with 18mm thick MDF board as per given drawing.	Nos	2			
2	Cabinet	Providing and fixing of Wooden Shelf for self-standing in 25mm thick commercial board including (BWP, termite resistant) & 1 mm laminate, 2 mm thick PVC lipping glued with hot melt EVA glue on all exposed surfaces, complete etc. - Depth-300mm .The unit to be fixed on the floor with dimension of each compartment as per drawing. (partition 2400mm (H) x600mm (D) x 1200mm (L)	Sqmt	5.76			
		Total Amount					
		GST @ 18%					
		Total Amount with GST					

Note: Agency must have visited site and made themselves aware of site conditions. All rates to be inclusive cost of Transportation, Labour, Materials etc. as required for satisfactory completion of work.. All accessories/ incidentals etc. as required for the installations and completion of the works are to be included and no extras shall be paid.

In words Rs) (_____)

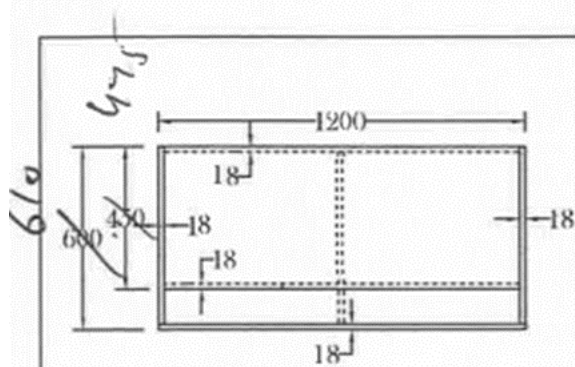

Size :- W1200 X D600 X H2100mm -
 Complete Storage Made of MDF board
 Laminate :- Merino - Asian Maple (10175)
 #Hinges :- Hettich - Soft Close (As per specs. sheet).
 #Lock :- Hettich (As per specs. sheet).
 #Handle :- As sample approved.

